

DATA SHEET

TDA8012M

Low power PLL FM demodulator
for satellite TV receivers

Product specification
Supersedes data of 1995 Feb 02
File under Integrated Circuits, IC02

1996 Mar 26

Low power PLL FM demodulator for satellite TV receivers

TDA8012M

FEATURES

- High input sensitivity
- Fully balanced two-pin Voltage Controlled Oscillator (VCO)
- Low input impedance (50 Ω)
- Low impedance video baseband output
- Internal voltage stabilizer
- Keyed AFC or peak-to-peak AFC
- Carrier detector
- AGC output
- Suitable for High Definition TV (HDTV).

APPLICATIONS

- Direct Broadcast Satellite (DBS) receivers.

GENERAL DESCRIPTION

The TDA8012M is a sensitive PLL FM demodulator which is used for the second IF in satellite receivers. It provides Automatic Gain Control (AGC) and Automatic Frequency Control (AFC) outputs that can be used to optimize the level and frequency of the input signal. During the searching procedure, the AFC output provides a signal which is used for carrier detection.

QUICK REFERENCE DATA

SYMBOL	PARAMETER	CONDITION	MIN.	TYP.	MAX.	UNIT
V_{CC}	supply voltage		4.5	5.0	5.5	V
I_{CC}	supply current	$V_{CC} = 5\text{ V}; T_{amb} = 25\text{ }^\circ\text{C}$	50	60	70	mA
V_i	input signal voltage level		53	57	61	dB μ V
$V_{o(p-p)}$	video output signal voltage amplitude (peak-to-peak value)	$\Delta f_o = 25\text{ MHz (p-p)}$	–	1	–	V
f_i	operating input frequency		–	480	–	MHz

ORDERING INFORMATION

TYPE NUMBER	PACKAGES		
	NAME	DESCRIPTION	VERSION
TDA8012M	SSOP20	plastic shrink small outline package; 20 leads; body width 4.4 mm	SOT266-1

Low power PLL FM demodulator for satellite TV receivers

TDA8012M

BLOCK DIAGRAM

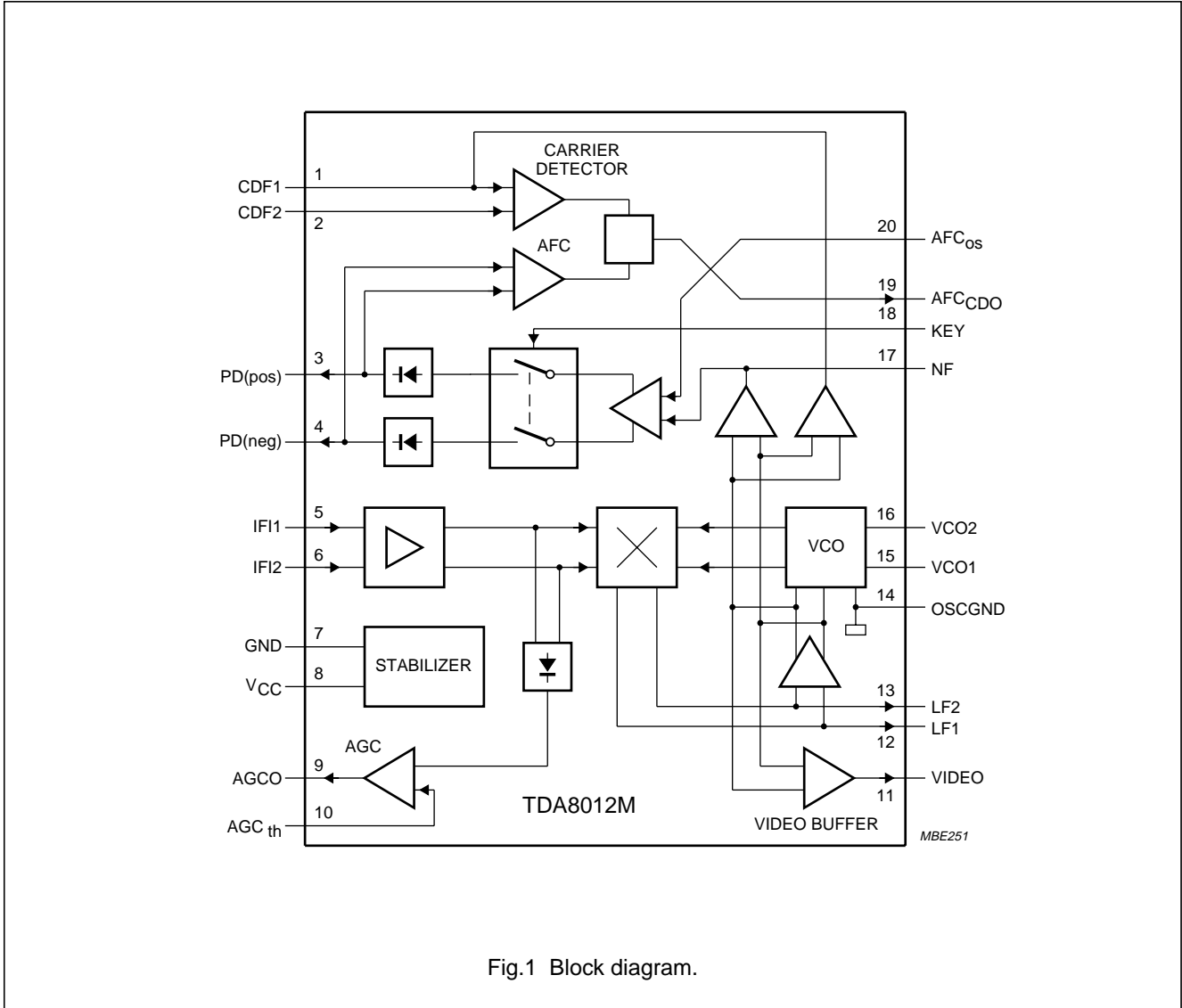

Fig.1 Block diagram.

Low power PLL FM demodulator for satellite TV receivers

TDA8012M

PINNING

SYMBOL	PIN	DESCRIPTION
CDF1	1	carrier detector filter 1 input
CDF2	2	carrier detector filter 2 input
PD(pos)	3	positive peak detector output
PD(neg)	4	negative peak detector output
IFI1	5	IF input 1
IFI2	6	IF input 2
GND	7	ground
V _{CC}	8	supply voltage
AGCO	9	AGC output
AGC _{th}	10	AGC threshold voltage input
VIDEO	11	baseband signal output
LF1	12	loop filter 1 input
LF2	13	loop filter 2 input
OSCGND	14	oscillator ground
VCO1	15	oscillator tank circuit 1 input
VCO2	16	oscillator tank circuit 2 input
NF	17	noise filter input
KEY	18	key pulse input
AFC _{CDO}	19	AFC and carrier detector output
AFC _{os}	20	AFC offset input

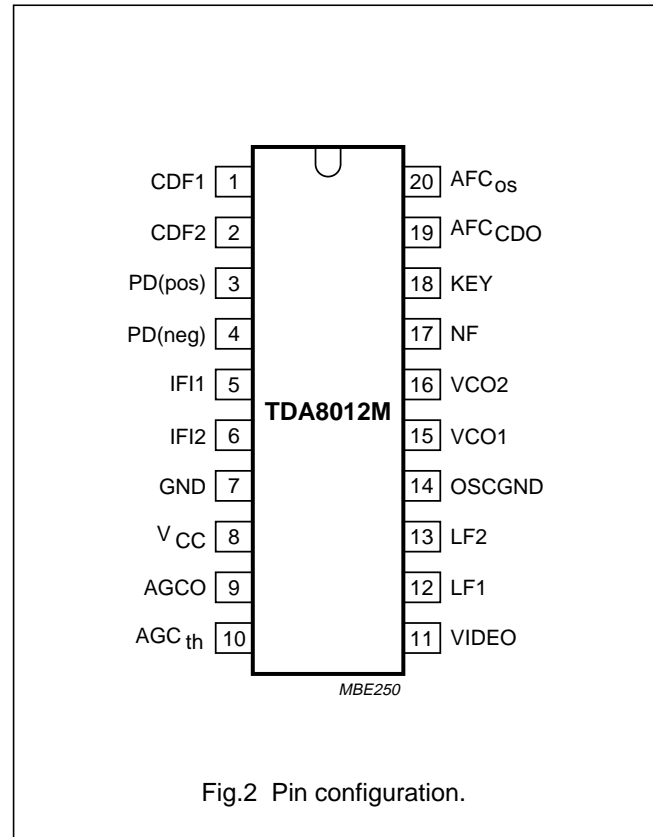

Fig.2 Pin configuration.

FUNCTIONAL DESCRIPTION

The TDA8012M is a low power PLL FM demodulator designed for use in satellite TV reception systems.

The demodulator is based on a Phase-Locked Loop (PLL) structure including a fully balanced two-pin VCO. A high gain IF amplifier ensures a high input sensitivity. The video output voltage is supplied via a highly linear video buffer which has a low output impedance. The centre frequency of the VCO and the loop characteristics can be set using external components.

The circuit provides an AGC signal which is used to drive a gain-controlled IF amplifier (TDA8011T or TDA8010M) to ensure a stable PLL demodulation characteristic.

An analog AFC voltage is also made available. This signal can be suitably applied to the input of the ADC port of the PLL frequency synthesizer (TSA5055). The AFC function may be keyed to address D2MAC and MUSE systems.

The TDA8012M includes a Carrier Detector (CD) which is used for channel detection during search procedures.

Low power PLL FM demodulator for satellite TV receivers

TDA8012M

LIMITING VALUES

In accordance with the Absolute Maximum Rating System (IEC 134).

SYMBOL	PARAMETER	MIN.	MAX.	UNIT
V_{CC}	supply voltage	-0.3	6.0	V
$V_{i(max)}$	maximum input voltage on all pins	-0.3	V_{CC}	V
$I_{source(max)}$	maximum output source current	-	10	mA
t_{sc}	maximum short-circuit time on all outputs	-	10	s
Z_L	AC load impedance at video output	600	-	Ω
T_{stg}	storage temperature	-55	+150	$^{\circ}C$
T_j	junction temperature	-	+150	$^{\circ}C$
T_{amb}	operating ambient temperature	-10	+80	$^{\circ}C$

HANDLING

Inputs and outputs are protected against electrostatic discharge in normal handling. However, to be totally safe it is desirable to take normal precautions appropriate to handling MOS devices.

THERMAL CHARACTERISTICS

SYMBOL	PARAMETER	VALUE	UNIT
$R_{th\ j-a}$	thermal resistance from junction to ambient in free air	120	K/W

CHARACTERISTICS

$V_{CC} = 5\text{ V}$; $f_i = 480\text{ MHz}$; $V_i = 57\text{ dB}\mu\text{V}$; $T_{amb} = 25\text{ }^{\circ}C$; measured in application circuit of Fig.4; unless otherwise specified.

SYMBOL	PARAMETER	CONDITIONS	MIN.	TYP.	MAX.	UNIT
Supplies						
V_{CC}	supply voltage		4.75	5.0	5.25	V
I_{CC}	supply current	note 1	50	60	70	mA
Voltage controlled oscillator						
K_{VCO}	voltage controlled oscillator constant	$V_{CC} = 4.75\text{ to }5.25\text{ V}$; $T_{amb} = -10\text{ to }+80\text{ }^{\circ}C$	22.5	25	27.5	MHz/V
$\delta f_o/\delta T$	voltage controlled oscillator drift	note 2	-	-70×10^{-6}	-	$^{\circ}C^{-1}$
Δf_o	voltage controlled oscillator shift	$V_{CC} = 4.75\text{ to }5.25\text{ V}$	-	-	± 750	kHz
Frequency demodulator						
V_i	input signal voltage level	note 3	53	57	61	$\text{dB}\mu\text{V}$
Z_i	input impedance	real part; note 4	-	50	-	Ω
		parallel inductive part; note 4	-	130	-	nH
K_{PD}	phase detector constant	$V_i = 57\text{ dB}\mu\text{V}$	-	0.37	-	V/rad
G_v	phase-lock loop gain	drift; note 5	-	2	-	dB
		shift; note 5	-	2	-	dB

Low power PLL FM demodulator for satellite TV receivers

TDA8012M

SYMBOL	PARAMETER	CONDITIONS	MIN.	TYP.	MAX.	UNIT
$Z_{o(\text{diff})}$	differential output impedance of the phase detector		1.6	2	2.4	$k\Omega$
CR_{PLL}	phase-lock loop capture range	note 6	–	± 17	–	MHz
G_{diff}	differential gain	note 7	–	± 2	–	%
Φ_{diff}	differential phase	note 7	–	± 2	–	deg
IM3	third-order intermodulation distortion	note 8	50	–	–	dB
Video output						
$V_{o(p-p)}$	baseband output signal amplitude (peak-to-peak value)	$\Delta f_o = 25 \text{ MHz}$	0.9	1.0	1.1	V
$V_{O(\text{DC})}$	DC voltage level of video output		2.1	2.35	2.6	V
Z_o	output impedance		–	10	50	Ω
Automatic gain control (note 9)						
AGC_{th}	AGC threshold as a function of the voltage applied to pin 10	$I_{\text{AGC}} = 0.5 \text{ mA}; 0.1V_{\text{CC}}$	–	–	53	$\text{dB}\mu\text{V}$
		$I_{\text{AGC}} = 0.5 \text{ mA}; 0.9V_{\text{CC}}$	61	–	–	$\text{dB}\mu\text{V}$
LD	level detector	shift; $V_{\text{CC}} = 4.75 \text{ to } 5.25 \text{ V}$	–	1	–	dB
		drift; $T_{\text{amb}} = -10 \text{ to } +80 \text{ }^\circ\text{C}$	–	1	–	dB
	AGC steepness	$I_{\text{AGC}} = 0.5 \text{ mA}; \text{note } 10$	–	8	–	mA/dB
$V_{\text{sat(AGC)}}$	low level AGC output saturation voltage	$I_{\text{AGC}} = 1 \text{ mA}$	–	200	500	mV
Keying pulse						
t_{key}	input keyed pulse time period		–	64	–	μs
$t_{W(\text{key})}$	keyed pulse width		8	–	–	μs
V_{IL}	LOW level input keyed pulse voltage	key on	–	–	0.8	V
V_{IH}	HIGH level input keyed pulse voltage	key off	2.7	–	–	V
Z_i	input impedance		1	–	–	$k\Omega$
AFC and carrier detector output (note 11)						
$\delta V_{\text{AFC}}/\delta f_r$	AFC steepness		4.9	5.5	6.1	V/MHz
$\text{AFC}_{\text{shift}}$	shift of AFC voltage in relation to VCO shift with unmodulated 480 MHz input signal	$\Delta V_{\text{CC}} = \pm 5\%$	–	± 180	± 500	kHz
$\text{AFC}_{\text{drift}}$	drift of AFC voltage in relation to the VCO	$T_{\text{amb}} = 80 \text{ }^\circ\text{C}; \text{note } 12$	–	–400	–	kHz

**Low power PLL FM demodulator
for satellite TV receivers**

TDA8012M**Notes**

1. The DC supply current is defined for $V_{CC} = 5\text{ V}$.
2. This typical value of $-70\text{ ppm}/^{\circ}\text{C}$ or $-70 \times 10^{-6}\text{ }^{\circ}\text{C}^{-1}$ can be found in the reference measuring set-up shown in Fig.3. The temperature drift may be adjusted by the temperature coefficient of the external capacitor in the tank circuit.
3. The circuit is designed for an input level of $57\text{ dB}\mu\text{V}$. The maximum allowable input level is $61\text{ dB}\mu\text{V}$. However, for levels other than $57\text{ dB}\mu\text{V}$ the optimum loop filter values will be different from those given for the $57\text{ dB}\mu\text{V}$ input level in the reference measuring set-up.
4. The input impedance is reduced to a resistor with a parallel reactance. The values are given at 480 MHz . In order to reduce the radiation from the oscillator to the RF input, it is recommended to use a symmetrical drive.
5. The PLL loop gain shift and drift are given without loop filter shift and drift (non-temperature compensated external components).
6. The capture range or lock-in range is defined as the PLL normal operating range. This value depends strongly on the loop filter characteristics.
7. Measurements with test signals in accordance with CCIR recommendation 473-3. FM modulated signal with DBS parameters:
 - a) 625 lines PAL TV system
 - b) 25 MHz/V modulator sensitivity
 - c) 1 V (p-p) video signal
 - d) No SAW filter is used.
8. No SAW filter is used at the input:
 - a) 16 MHz/V modulator sensitivity
 - b) 4.43 MHz sine wave colour signal [660 mV (p-p)]
 - c) 3.25 MHz sine wave luminance signal [700 mV (p-p)]
 - d) Two Wegner sound sub-carriers at 7.02 and 7.2 MHz (100 mV)
 - e) Intermodulation distance is defined as the distance between the luminance signal and the intermodulation products.
9. The characteristics of the AGC function are measured in the application circuit of Fig.4. The circuit illustrated in Fig.4 has been designed to set the maximum AGC current of 1 mA. The output of the AGC function is capable of handling up to 5 mA. The maximum AGC current can be increased to 5 mA by decreasing the value of the resistor connected between pins 8 and 9.
10. In the application circuit (see Fig.4) the voltage at the AGC output decreases when the IF input level increases above the adjusted AGC threshold.
11. The outputs from the AFC and carrier detector are combined at pin 19 (see Fig.3). During search tuning, when the input frequency is outside the capture range, the combined output (carrier detector function) is at a LOW level (any voltage below $0.6V_{CC}$). When the PLL becomes locked, the voltage at pin 19 rises to a HIGH level ($V_{19} = 0.8V_{CC}$ to V_{CC}). When the input channel is close to the centre frequency, V_{19} falls to the LOW level. As shown in Fig.3, the voltage at pin 19 is now a function of the centre frequency (AFC function). This information may be read by a microcontroller via the ADC of the satellite frequency synthesizer (TSA5055) and the I²C-bus.
12. The drift of the AFC voltage is measured in accordance with the following method:
 - a) At room temperature ($T_{\text{amb}} = 25\text{ }^{\circ}\text{C}$) the TDA8012M is driven by a 480 MHz unmodulated signal. The voltage at pin 20 must be adjusted to obtain a 1.5 V output at the AFC output (pin 19).
 - b) At $T_{\text{amb}} = 80\text{ }^{\circ}\text{C}$, due to its temperature drift, the AFC output voltage differs from 1.5 V. The input frequency must, therefore, be adjusted to obtain 1.5 V at the AFC output. The drift of the AFC voltage will then be equal to the difference between the new input frequency and 480 MHz .

Low power PLL FM demodulator
for satellite TV receivers

TDA8012M

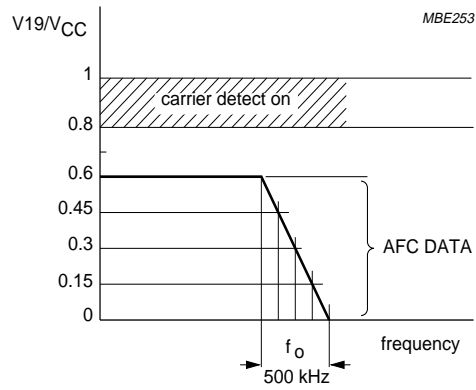

Fig.3 AFC and carrier detector output.

Low power PLL FM demodulator
for satellite TV receivers

TDA8012M

APPLICATION INFORMATION

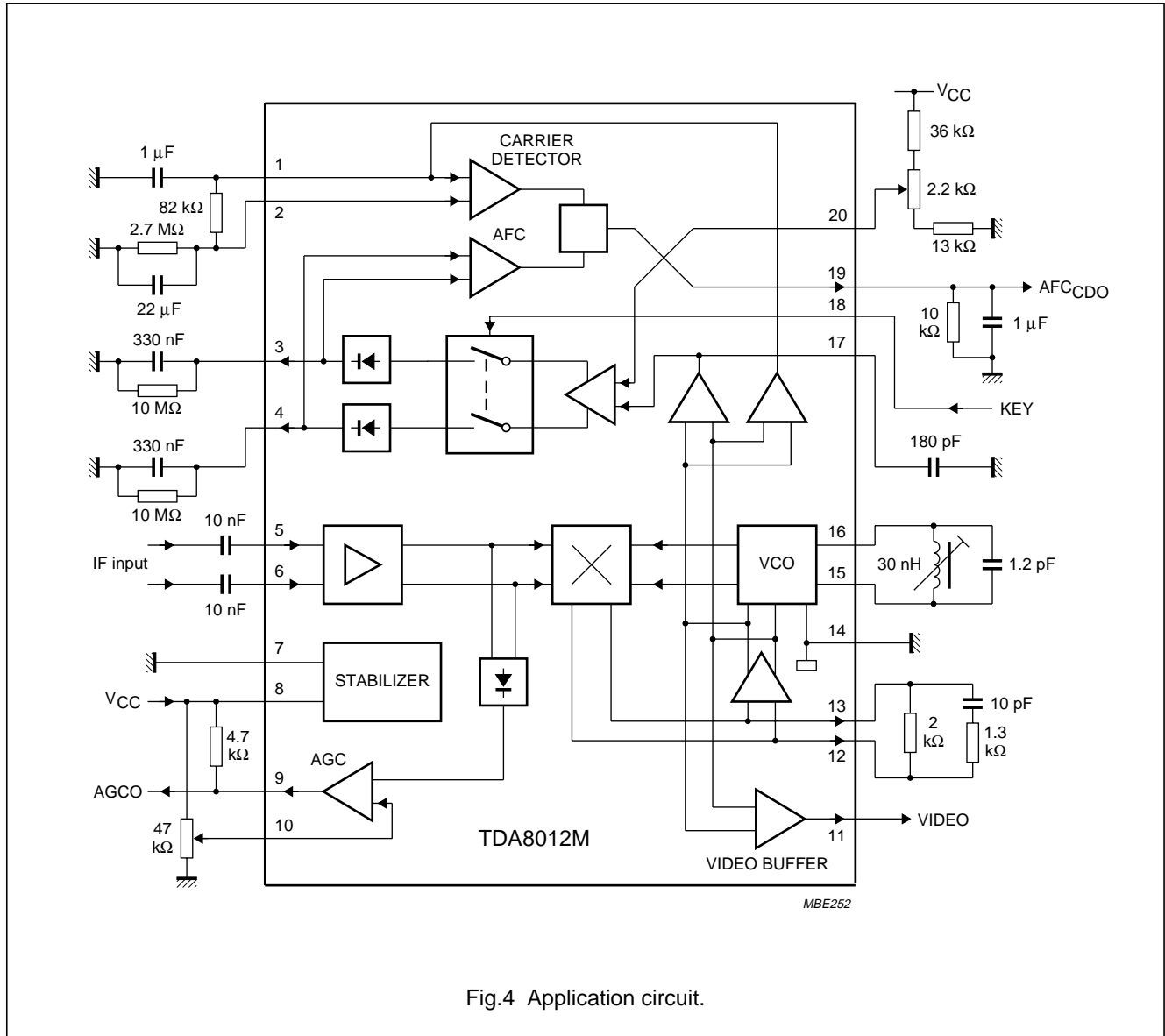

Fig.4 Application circuit.

Low power PLL FM demodulator
for satellite TV receivers

TDA8012M

PACKAGE OUTLINE

SSOP20: plastic shrink small outline package; 20 leads; body width 4.4 mm

SOT266-1

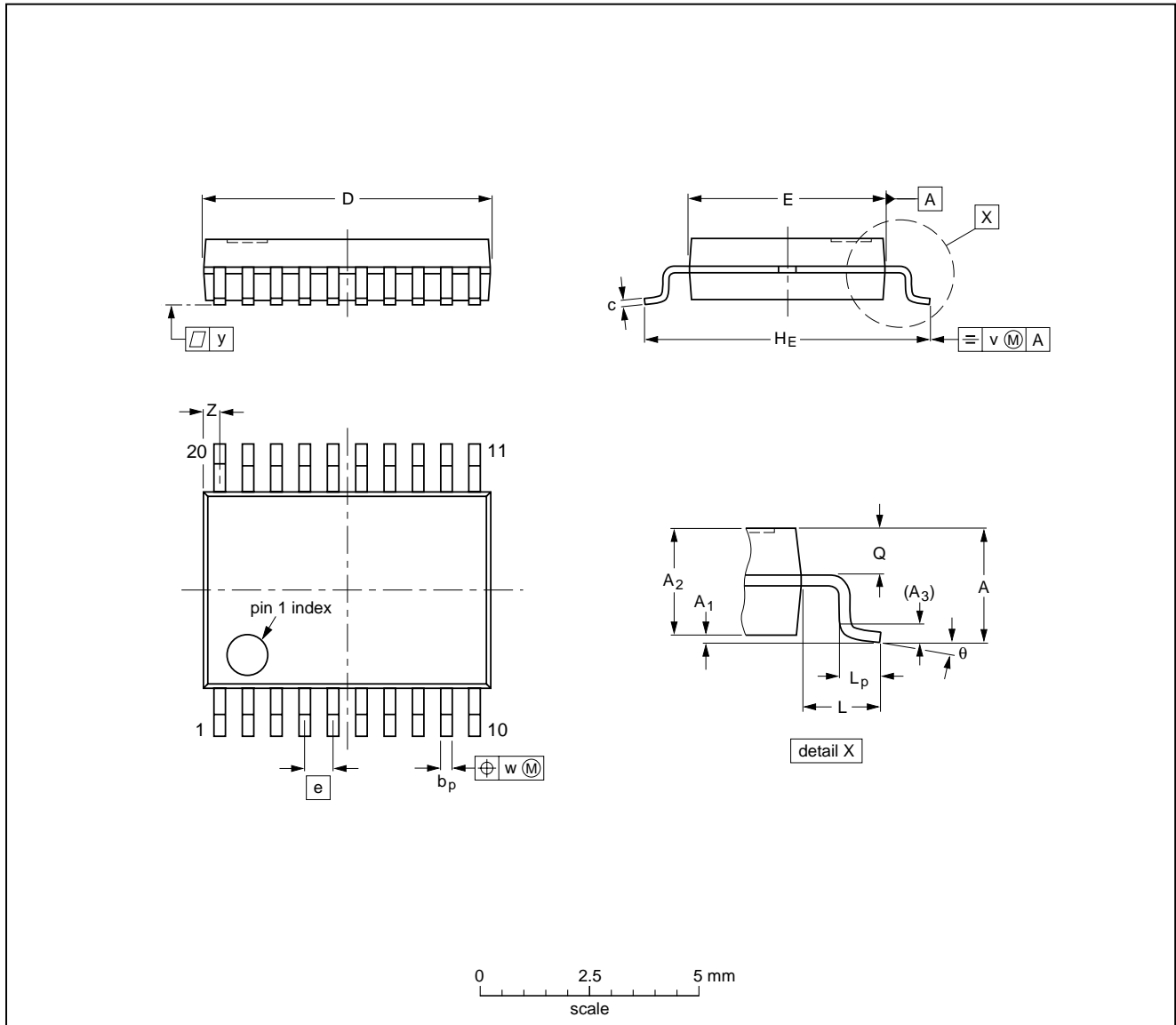

DIMENSIONS (mm are the original dimensions)

UNIT	A max.	A ₁	A ₂	A ₃	b _p	c	D ⁽¹⁾	E ⁽¹⁾	e	H _E	L	L _p	Q	v	w	y	Z ⁽¹⁾	θ
mm	1.5	0.15 0	1.4 1.2	0.25	0.32 0.20	0.20 0.13	6.6 6.4	4.5 4.3	0.65	6.6 6.2	1.0	0.75 0.45	0.65 0.45	0.2	0.13	0.1	0.48 0.18	10° 0°

Note

1. Plastic or metal protrusions of 0.20 mm maximum per side are not included.

OUTLINE VERSION	REFERENCES				EUROPEAN PROJECTION	ISSUE DATE
	IEC	JEDEC	EIAJ			
SOT266-1						90-04-05 95-02-25

Low power PLL FM demodulator for satellite TV receivers

TDA8012M

SOLDERING

Introduction

There is no soldering method that is ideal for all IC packages. Wave soldering is often preferred when through-hole and surface mounted components are mixed on one printed-circuit board. However, wave soldering is not always suitable for surface mounted ICs, or for printed-circuits with high population densities. In these situations reflow soldering is often used.

This text gives a very brief insight to a complex technology. A more in-depth account of soldering ICs can be found in our "*IC Package Databook*" (order code 9398 652 90011).

Reflow soldering

Reflow soldering techniques are suitable for all SSOP packages.

Reflow soldering requires solder paste (a suspension of fine solder particles, flux and binding agent) to be applied to the printed-circuit board by screen printing, stencilling or pressure-syringe dispensing before package placement.

Several techniques exist for reflowing; for example, thermal conduction by heated belt. Dwell times vary between 50 and 300 seconds depending on heating method. Typical reflow temperatures range from 215 to 250 °C.

Preheating is necessary to dry the paste and evaporate the binding agent. Preheating duration: 45 minutes at 45 °C.

Wave soldering

Wave soldering is **not** recommended for SSOP packages. This is because of the likelihood of solder bridging due to closely-spaced leads and the possibility of incomplete solder penetration in multi-lead devices.

If wave soldering cannot be avoided, the following conditions must be observed:

- **A double-wave (a turbulent wave with high upward pressure followed by a smooth laminar wave) soldering technique should be used.**
- **The longitudinal axis of the package footprint must be parallel to the solder flow and must incorporate solder thieves at the downstream end.**

Even with these conditions, only consider wave soldering SSOP packages that have a body width of 4.4 mm, that is SSOP16 (SOT369-1) or SSOP20 (SOT266-1).

During placement and before soldering, the package must be fixed with a droplet of adhesive. The adhesive can be applied by screen printing, pin transfer or syringe dispensing. The package can be soldered after the adhesive is cured.

Maximum permissible solder temperature is 260 °C, and maximum duration of package immersion in solder is 10 seconds, if cooled to less than 150 °C within 6 seconds. Typical dwell time is 4 seconds at 250 °C.

A mildly-activated flux will eliminate the need for removal of corrosive residues in most applications.

Repairing soldered joints

Fix the component by first soldering two diagonally-opposite end leads. Use only a low voltage soldering iron (less than 24 V) applied to the flat part of the lead. Contact time must be limited to 10 seconds at up to 300 °C. When using a dedicated tool, all other leads can be soldered in one operation within 2 to 5 seconds between 270 and 320 °C.

**Low power PLL FM demodulator
for satellite TV receivers**

TDA8012M

DEFINITIONS

Data sheet status	
Objective specification	This data sheet contains target or goal specifications for product development.
Preliminary specification	This data sheet contains preliminary data; supplementary data may be published later.
Product specification	This data sheet contains final product specifications.
Limiting values	
Limiting values given are in accordance with the Absolute Maximum Rating System (IEC 134). Stress above one or more of the limiting values may cause permanent damage to the device. These are stress ratings only and operation of the device at these or at any other conditions above those given in the Characteristics sections of the specification is not implied. Exposure to limiting values for extended periods may affect device reliability.	
Application information	
Where application information is given, it is advisory and does not form part of the specification.	

LIFE SUPPORT APPLICATIONS

These products are not designed for use in life support appliances, devices, or systems where malfunction of these products can reasonably be expected to result in personal injury. Philips customers using or selling these products for use in such applications do so at their own risk and agree to fully indemnify Philips for any damages resulting from such improper use or sale.

Low power PLL FM demodulator
for satellite TV receivers

TDA8012M

NOTES

Low power PLL FM demodulator
for satellite TV receivers

TDA8012M

NOTES

Low power PLL FM demodulator
for satellite TV receivers

TDA8012M

NOTES

Philips Semiconductors – a worldwide company

Argentina: see South America

Australia: 34 Waterloo Road, NORTH RYDE, NSW 2113,
Tel. (02) 805 4455, Fax. (02) 805 4466

Austria: Computerstr. 6, A-1101 WIEN, P.O. Box 213,
Tel. (01) 60 101-1256, Fax. (01) 60 101-1250

Belarus: Hotel Minsk Business Center, Bld. 3, r. 1211,
Volodarski Str. 6, 220050 MINSK,
Tel. (172) 200 733, Fax. (172) 200 773

Belgium: see The Netherlands

Brazil: see South America

Bulgaria: Philips Bulgaria Ltd., Energoproject, 15th floor,
51 James Bourchier Blvd., 1407 SOFIA,
Tel. (359) 2 689 211, Fax. (359) 2 689 102

Canada: PHILIPS SEMICONDUCTORS/COMPONENTS:
Tel. (800) 234-7381, Fax. (708) 296-8556

Chile: see South America

China/Hong Kong: 501 Hong Kong Industrial Technology Centre,
72 Tat Chee Avenue, Kowloon Tong, HONG KONG,
Tel. (852) 2319 7888, Fax. (852) 2319 7700

Colombia: see South America

Czech Republic: see Austria

Denmark: Prags Boulevard 80, PB 1919, DK-2300
COPENHAGEN S, Tel. (032) 88 2636, Fax. (031) 57 1949

Finland: Sinikalliontie 3, FIN-02630 ESPOO,
Tel. (358) 0-615 800, Fax. (358) 0-61580 920

France: 4 Rue du Port-aux-Vins, BP317,
92156 SURESNES Cedex,
Tel. (01) 4099 6161, Fax. (01) 4099 6427

Germany: P.O. Box 10 51 40, 20035 HAMBURG,
Tel. (040) 23 53 60, Fax. (040) 23 53 63 00

Greece: No. 15, 25th March Street, GR 17778 TAVROS,
Tel. (01) 4894 339/4894 911, Fax. (01) 4814 240

Hungary: see Austria

India: Philips INDIA Ltd, Shivsagar Estate, A Block,
Dr. Annie Besant Rd. Worli, BOMBAY 400 018
Tel. (022) 4938 541, Fax. (022) 4938 722

Indonesia: see Singapore

Ireland: Newstead, Clonskeagh, DUBLIN 14,
Tel. (01) 7640 000, Fax. (01) 7640 200

Israel: RAPAC Electronics, 7 Kehilat Saloniki St, TEL AVIV 61180,
Tel. (03) 645 04 44, Fax. (03) 648 10 07

Italy: PHILIPS SEMICONDUCTORS,
Piazza IV Novembre 3, 20124 MILANO,
Tel. (0039) 2 6752 2531, Fax. (0039) 2 6752 2557

Japan: Philips Bldg 13-37, Kohnan 2-chome, Minato-ku,
TOKYO 108, Tel. (03) 3740 5130, Fax. (03) 3740 5077

Korea: Philips House, 260-199 Itaewon-dong,
Yongsan-ku, SEOUL, Tel. (02) 709-1412, Fax. (02) 709-1415

Malaysia: No. 76 Jalan Universiti, 46200 PETALING JAYA,
SELANGOR, Tel. (03) 750 5214, Fax. (03) 757 4880

Mexico: 5900 Gateway East, Suite 200, EL PASO,
TEXAS 79905, Tel. 9-5(800) 234-7831, Fax. (708) 296-8556

Middle East: see Italy

Netherlands: Postbus 90050, 5600 PB EINDHOVEN, Bldg. VB,
Tel. (040) 2783749, Fax. (040) 2788399

New Zealand: 2 Wagener Place, C.P.O. Box 1041, AUCKLAND,
Tel. (09) 849-4160, Fax. (09) 849-7811

Norway: Box 1, Manglerud 0612, OSLO,
Tel. (022) 74 8000, Fax. (022) 74 8341

Philippines: PHILIPS SEMICONDUCTORS PHILIPPINES Inc.,
106 Valero St. Salcedo Village, P.O. Box 2108 MCC,
MAKATI, Metro MANILA,
Tel. (63) 2 816 6380, Fax. (63) 2 817 3474

Poland: Ul. Lukiska 10, PL 04-123 WARSZAWA,
Tel. (022) 612 2831, Fax. (022) 612 2327

Portugal: see Spain

Romania: see Italy

Singapore: Lorong 1, Toa Payoh, SINGAPORE 1231,
Tel. (65) 350 2000, Fax. (65) 251 6500

Slovakia: see Austria

Slovenia: see Italy

South Africa: S.A. PHILIPS Pty Ltd.,
195-215 Main Road Martindale, 2092 JOHANNESBURG,
P.O. Box 7430 Johannesburg 2000,
Tel. (011) 470-5911, Fax. (011) 470-5494

South America: Rua do Rocio 220 - 5th floor, Suite 51,
CEP: 04552-903-SÃO PAULO-SP, Brazil,
P.O. Box 7383 (01064-970),
Tel. (011) 821-2333, Fax. (011) 829-1849

Spain: Balmes 22, 08007 BARCELONA,
Tel. (03) 301 6312, Fax. (03) 301 4107

Sweden: Kottbygatan 7, Akalla. S-16485 STOCKHOLM,
Tel. (0) 8-632 2000, Fax. (0) 8-632 2745

Switzerland: Allmendstrasse 140, CH-8027 ZÜRICH,
Tel. (01) 488 2211, Fax. (01) 481 77 30

Taiwan: PHILIPS TAIWAN Ltd., 23-30F, 66,
Chung Hsiao West Road, Sec. 1, P.O. Box 22978,
TAIPEI 100, Tel. (886) 2 382 4443, Fax. (886) 2 382 4444

Thailand: PHILIPS ELECTRONICS (THAILAND) Ltd.,
209/2 Sanpavuth-Bangna Road Prakanong, BANGKOK 10260,
Tel. (66) 2 745-4090, Fax. (66) 2 398-0793

Turkey: Talatpasa Cad. No. 5, 80640 GÜLTEPE/ISTANBUL,
Tel. (0212) 279 2770, Fax. (0212) 282 6707

Ukraine: PHILIPS UKRAINE,
2A Akademika Koroleva str., Office 165, 252148 KIEV,
Tel. 380-44-4760297, Fax. 380-44-4766991

United Kingdom: Philips Semiconductors LTD.,
276 Bath Road, Hayes, MIDDLESEX UB3 5BX,
Tel. (0181) 730-5000, Fax. (0181) 754-8421

United States: 811 East Arques Avenue, SUNNYVALE,
CA 94088-3409, Tel. (800) 234-7381, Fax. (708) 296-8556

Uruguay: see South America

Vietnam: see Singapore

Yugoslavia: PHILIPS, Trg N. Pasica 5/v, 11000 BEOGRAD,
Tel. (381) 11 825 344, Fax. (359) 211 635 777

Internet: <http://www.semiconductors.philips.com/ps/>

For all other countries apply to: Philips Semiconductors,
Marketing & Sales Communications, Building BE-p,
P.O. Box 218, 5600 MD EINDHOVEN, The Netherlands,
Fax. +31-40-2724825

SCDS48

© Philips Electronics N.V. 1996

All rights are reserved. Reproduction in whole or in part is prohibited without the prior written consent of the copyright owner.

The information presented in this document does not form part of any quotation or contract, is believed to be accurate and reliable and may be changed without notice. No liability will be accepted by the publisher for any consequence of its use. Publication thereof does not convey nor imply any license under patent- or other industrial or intellectual property rights.

Printed in The Netherlands

537021/1100/02/pp16
Document order number:

Date of release: 1996 Mar 26
9397 750 00766